

Ultra- Flexible SF Type (large diameter)

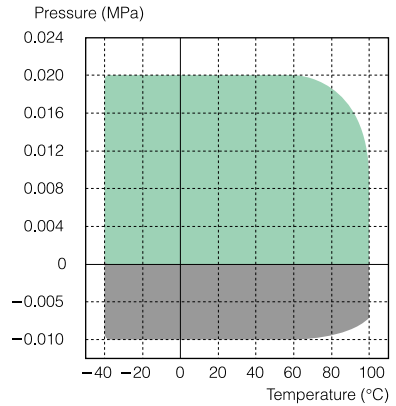
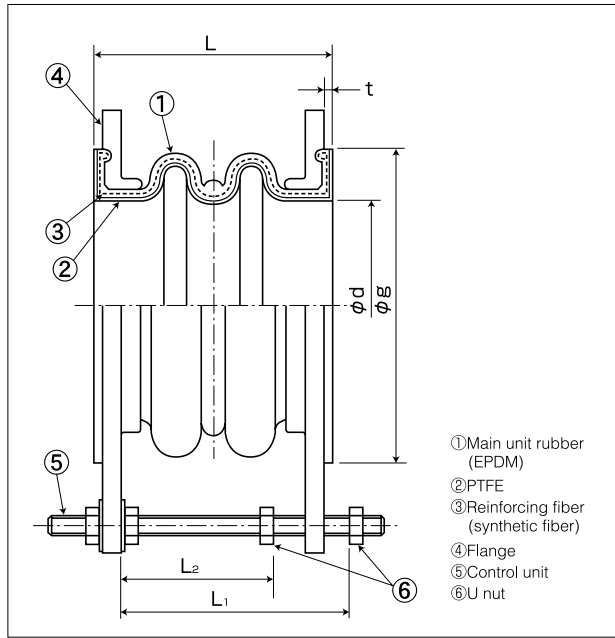

Working range applicable when combined displacement is 50% or lower.
 Working range applicable when combined displacement exceeds 50%.

Operating pressure: 0.02MPa (2kgf/cm²) or lower
 Negative pressure: -0.01MPa (-0.1kgf/cm²) or higher
 Operating temperature: -30°C~+100°C (Cooling and heating water)
 ● Before use, check that maximum working pressure and maximum working temperature are within operational ranges.

Standard dimensions and allowable displacements

Nominal diameter	Unit dimensions				Allowable displacement				Allowable displacement upon installation				Weight (kg)	Dimensions of control unit set			
	φd (mm)	φg (mm)	L (mm)	t (mm)	Expansion (mm)	Contraction (mm)	Eccentricity (mm)	Declination (°)	Expansion (mm)	Contraction (mm)	Eccentricity (mm)	Declination (°)		Reference (kg)	Bolt used	L ₁ (mm)	L ₂ (mm)
350	353	417	184	4.0	20	24	15	5	7	8	4	1	49.5	M-20	170	100	3
400	403	478	190	4.0	20	24	15	5	7	8	4	1	67.8	M-24	174	102	3
450	454	533	194	4.0	20	24	15	5	7	8	4	1	80.8	M-24	176	102	3
500	504	585	228	4.0	26	30	20	5	9	11	4	1	94.7	M-24	214	128	3
600	605	695	240	5.0	26	30	20	4	9	11	4	1	145.6	M-27	224	136	3
650	650	721	258	5.0	26	30	20	4	9	11	4	1	154.8	M-27	240	150	3
700	700	800	258	6.0	26	30	20	4	9	11	4	1	166.6	M-27	238	148	3
800	809	905	272	6.0	31	35	20	4	11	12	4	1	216.6	M-27	255	153	3

- Weights with SS400 or JIS10K flanges (standard) mounted are indicated.
- Dimension allowances on installation are included in allowable displacements.
 (Allowable displacement = Dimension allowances on installation + Displacement under operation)



Product features

- ① Ultra-flexible type PTFE inner surface coating type.
- ② Excellent chemical resistance employing PTFE (polyethylene tetrafluoride) on areas in contact with liquid (internal surface).
- ③ Increased resistance to external shocks due to integration of structure with durable, strong rubber.

Product applications

- ① Piping for corrosive gas in chemical plants.

*Specifications and structures are subject to change without notice for purposes of improvement.